



GUIL®

ULK 700



5.00 m
(16.40 ft)

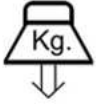

380 kg
(838 lb)



www.guil.es

MADE IN SPAIN





GUIL®

ULK 700

LIFTING TOWERS WITH 3 SAFETY SYSTEMS



Ref. **AL-KO OPTIMA 901**

AUTO-BRAKE WINCH.
COMPLIES WITH CE MACHINERY DIRECTIVES.



AUTOMATIC SAFETY
BLOCKING SYSTEM (ASB)



INTERNAL PENDULUM
BRAKE SYSTEM (IPB)



MAST SECTION
UNBLOCKING SYSTEM (MSU)



MAST SEQUENCE
CONTROL SYSTEM (MSC)



MORE MAST OVERLAP.
PREVENT FISHING ROD EFFECT.



DGUV Regulation 17&18

MADE IN SPAIN



TECHNICAL SPECIFICATIONS		ULK 700
WORKING HEIGHT	FORKS UP	5,00 m / 16.40 ft
	FORKS DOWN	4,50 m / 14.76 ft
MAXIMUM LOAD		380 kg / 838 lb
NET WEIGHT		173 kg / 381 lb
FOLDED DIMENSIONS		540 x 760 x 1980 mm / 1' 9.26" x 2' 5.92" x 6' 5.95"
LOADING HEIGHT		30 cm / 11.81"
No OF SECTIONS		3
WIDTH OF PROFILE		181 mm / 7.13"
AUTO BRAKE WINCH		Ref. AL-KO OPTIMA 901
MINIMUM LOAD WEIGHT		20 kg / 44.09 lb
MADE WITH		ALUMINIUM: EN-AW 6082 T6 - STEEL: S235 JRH
COLOUR		BLACK
COMPLIES WITH		DGUV Regulation 17&18, DGUV Rule 115-002, DIN 56950-1, 2006/42/CE



GUIL®

ULK 700

MADE IN SPAIN



LINE ARRAY

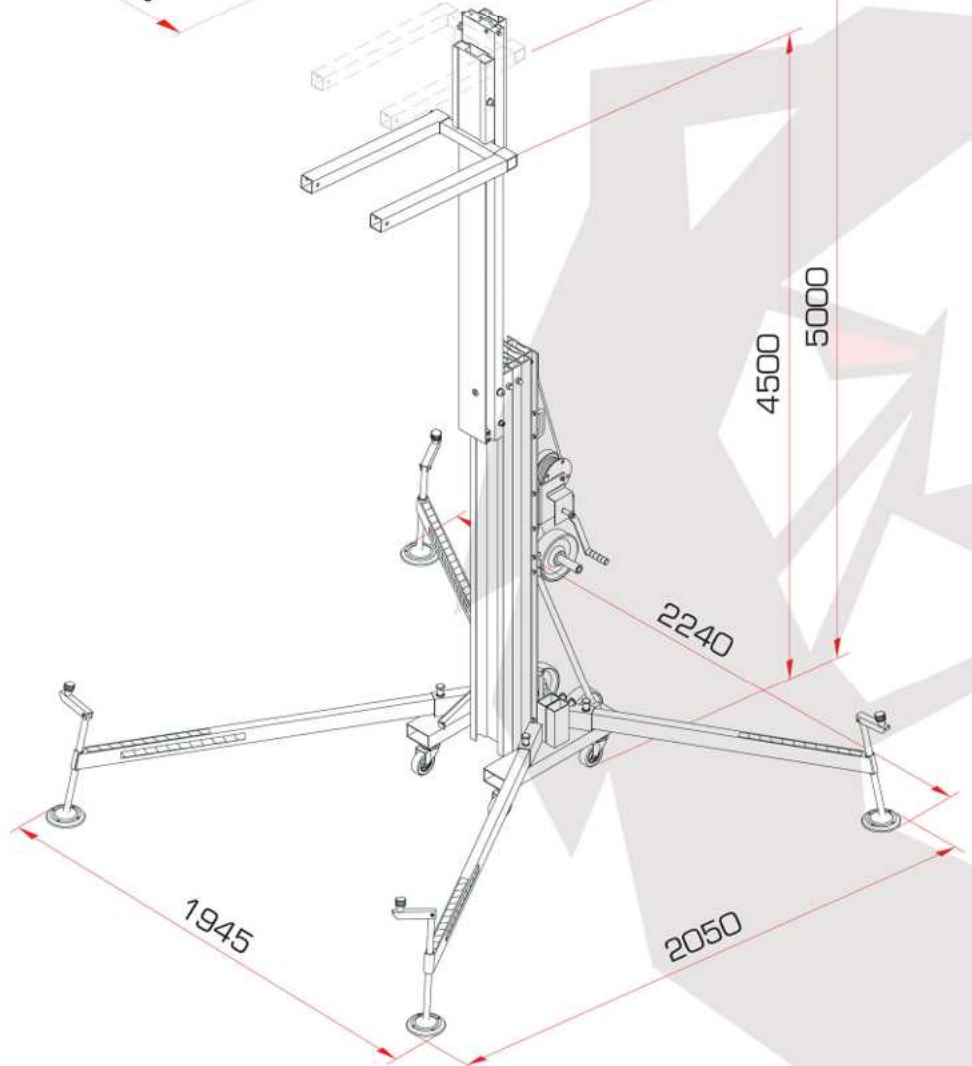
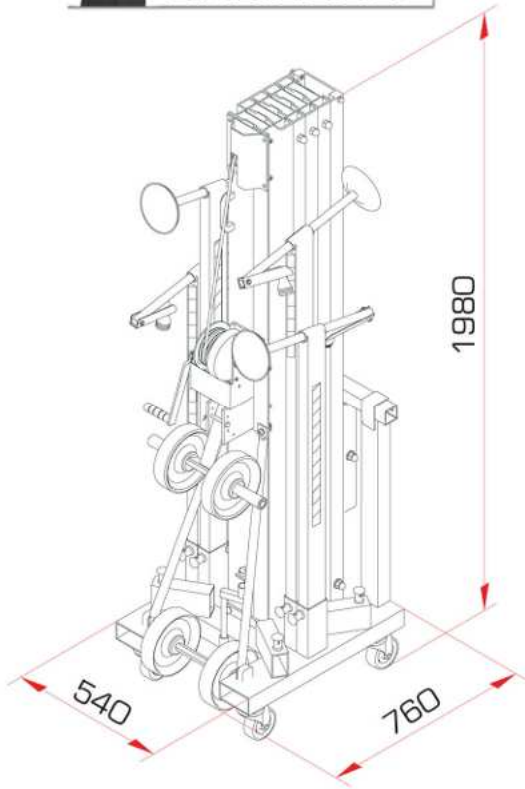
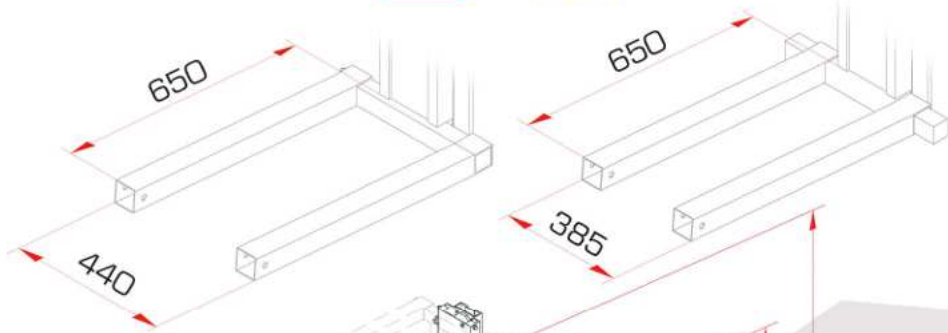

ADAPTORS FOR ULK TOWERS

ADAPTORS TO FLY LINE ARRAY SYSTEMS

SWIVEL ADAPTOR TO FIT TRUSSES TO ULK TOWERS



Ref. **ULK-A6**



Ref. **ULK-A10**



GUIL®

LIFTING TOWERS (FRONT-LOADER)

ULK



CE

DGUV Regulation 17&18

What makes our towers different?



Mast Section Unlocking System (MSU)



Automatic Safety Blocking System (ASB)



Auto-brake Winch.
Complies with CE Machinery Directives.



Internal Pendulum Brake System (IPB)

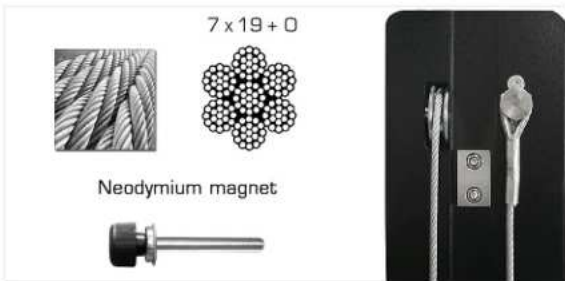

Reinforced Aluminium Sections. Galvanised steel wire rope. Stainless steel magnetic fastener bolts (Neodymium).



Cable resend system with steel pulleys.



4 heavy-duty wheels (Ø100mm) with aluminium core & steel fastening plates.



Fitted with 4 stabiliser braces for greater lift stability.



Leveller screw jacks with double thread for a quick adjustment & chrome foot plates with non-slip injection moulded rubber pads.



2 heavy-duty Ø200mm wheels for horizontal transportation & loading into vehicles.



U-shaped steel plate to reinforce the securing of the mast sections to the base. Integrated manual holder.



More mast overlap. Prevent fishing rod effect.



Fold-away handles with 2 heavy-duty Ø200mm wheels for horizontal transportation & loading into vehicles.



60x60 mm Reinforced forks. Maximum strength. Adjustable & detachable design. Fork carriage with two positions.