



# GUIL®

# ULK 600



**6.00 m**  
(19.70 ft)

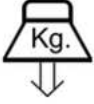

**320 kg**  
(705 lb)



1630 mm



MADE IN SPAIN

[www.guil.es](http://www.guil.es)





# GUIL®

# ULK 600

## LIFTING TOWERS WITH 3 SAFETY SYSTEMS



Ref. **AL-KO OPTIMA 901**

AUTO-BRAKE WINCH.  
COMPLIES WITH CE MACHINERY DIRECTIVES.



AUTOMATIC SAFETY  
BLOCKING SYSTEM (ASB)



INTERNAL PENDULUM  
BRAKE SYSTEM (IPB)



MAST SECTION  
UNBLOCKING SYSTEM (MSU)



MAST SEQUENCE  
CONTROL SYSTEM (MSC)



MORE MAST OVERLAP.  
PREVENT FISHING ROD EFFECT.



DGUV Regulation 17&18

MADE IN SPAIN



TECHNICAL SPECIFICATIONS		ULK 600
WORKING HEIGHT	FORKS UP	6,00 m / 19.70 ft
	FORKS DOWN	5,50 m / 18.04 ft
MAXIMUM LOAD		320 kg / 705 lb
NET WEIGHT		190 kg / 419 lb
FOLDED DIMENSIONS		540 x 760 x 1630 mm / 1' 9.26" x 2' 5.92" x 5' 4.17"
LOADING HEIGHT		30 cm / 11.81"
No OF SECTIONS		5
WIDTH OF PROFILE		181 mm / 7.13"
AUTO BRAKE WINCH		Ref. AL-KO OPTIMA 901
MINIMUM LOAD WEIGHT		20 kg / 44.09 lb
MADE WITH		ALUMINIUM: EN-AW 6082 T6 - STEEL: S235 JRH
COLOUR		BLACK
COMPLIES WITH		DGUV Regulation 17&18, DGUV Rule 115-002, DIN 56950-1, 2006/42/CE



# GUIL®

# ULK 600

MADE IN SPAIN



LINE ARRAY

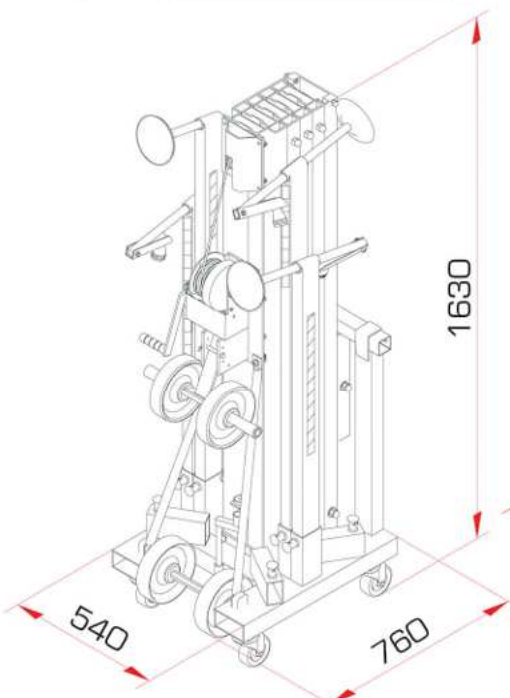
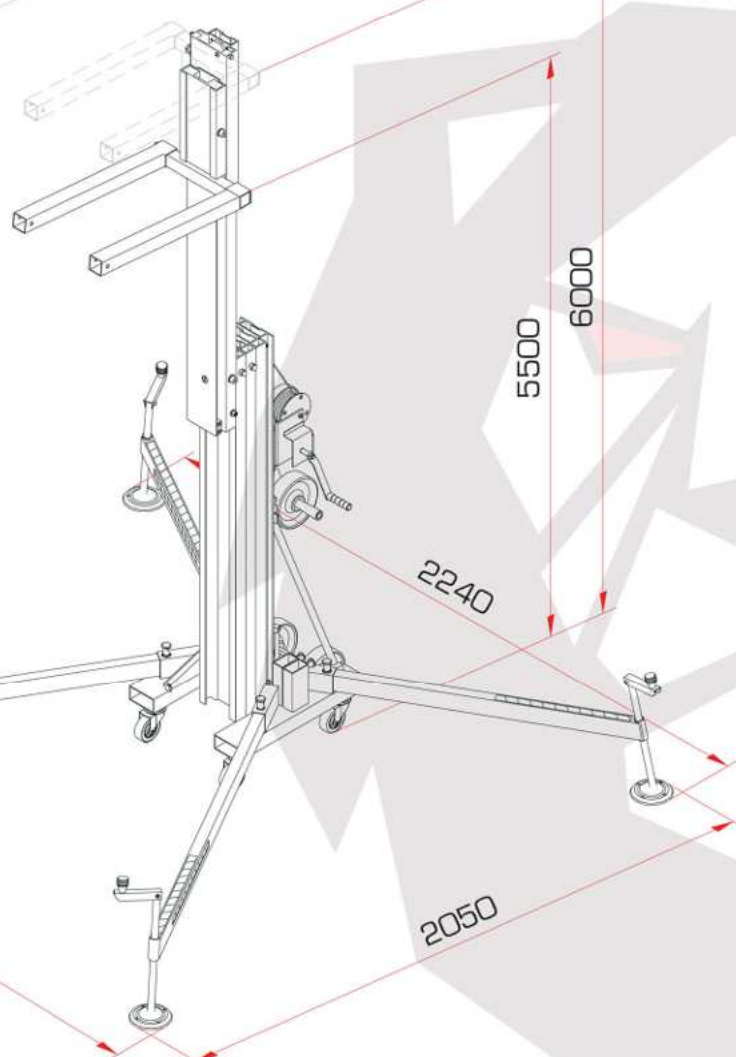
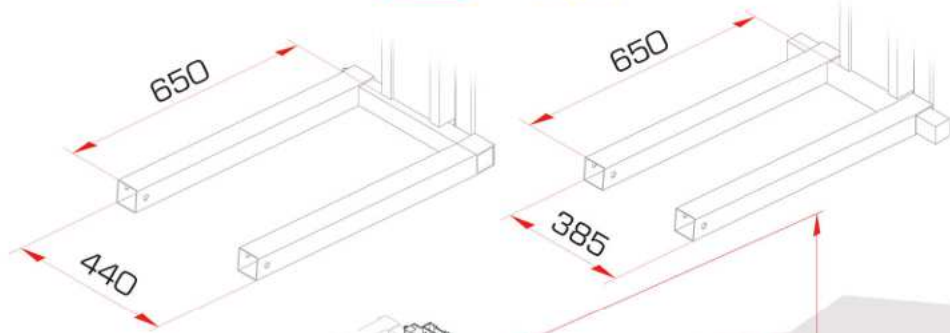

1630

1945

## ADAPTORS FOR ULK TOWERS

ADAPTORS TO FLY LINE ARRAY SYSTEMS

SWIVEL ADAPTOR TO FIT TRUSSES TO ULK TOWERS



Ref. **ULK-A6**



Ref. **ULK-A4**



Ref. **ULK-A10**



# GUIL®

LIFTING TOWERS (FRONT-LOADER)

## ULK



DGUV Regulation 17&18

### What makes our towers different?



Mast Section Unlocking System (MSU)



Automatic Safety Blocking System (ASB)



Auto-brake Winch .  
Complies with CE Machinery Directives.



Internal Pendulum Brake System (IPB)

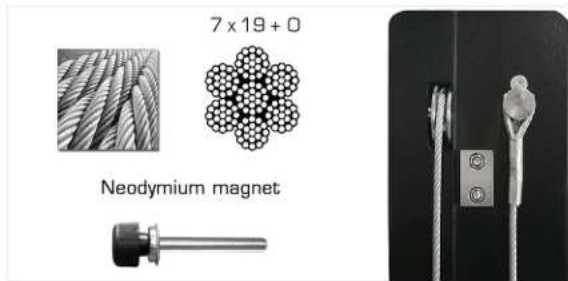

Reinforced Aluminium Sections. Galvanised steel wire rope. Stainless steel magnetic fastener bolts (Neodymium).



Cable resend system with steel pulleys.



4 heavy-duty wheels (Ø100mm) with aluminium core & steel fastening plates.



Fitted with 4 stabiliser braces for greater lift stability.



Leveller screw jacks with double thread for a quick adjustment & chrome foot plates with non-slip injection moulded rubber pads.



2 heavy-duty Ø200mm wheels for horizontal transportation & loading into vehicles.



U-shaped steel plate to reinforce the securing of the mast sections to the base. Integrated manual holder.



More mast overlap. Prevent fishing rod effect.



Fold-away handles with 2 heavy-duty Ø200mm wheels for horizontal transportation & loading into vehicles.



60x60 mm Reinforced forks. Maximum strength. Adjustable & detachable design. Fork carriage with two positions.