



GUIL®

ULK 500

↑ **6.30 m**
(20.70 ft)

Kg. **220 kg**
(485 lb)



1700 mm



MADE IN SPAIN



www.guil.es



GUIL®

ULK 500

LIFTING TOWERS WITH 3 SAFETY SYSTEMS



Ref. **AL-KO 900**

AUTO-BRAKE WINCH.
COMPLIES WITH CE MACHINERY DIRECTIVES.



AUTOMATIC SAFETY
BLOCKING SYSTEM (ASB)



INTERNAL PENDULUM
BRAKE SYSTEM (IPB)



MAST SECTION
UNBLOCKING SYSTEM (MSU)



MAST SEQUENCE
CONTROL SYSTEM (MSC)

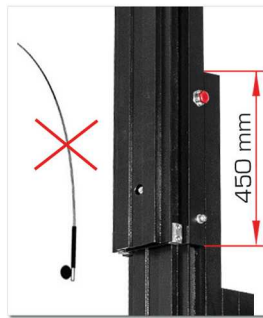

MORE MAST OVERLAP.
PREVENT FISHING ROD EFFECT.

CERTIFIED

DGUV Regulation 17&18

MADE IN SPAIN



TECHNICAL SPECIFICATIONS	ULK 500
WORKING HEIGHT	6,30 m / 20.70 ft
MAXIMUM LOAD	220 kg / 485 lb
NET WEIGHT	117 kg / 258 lb
FOLDED DIMENSIONS	570 x 460 x 1700 mm / 1' 10.44" x 1' 6.10" x 5' 6.92"
LOADING HEIGHT	19 cm / 7.48"
No OF SECTIONS	5
WIDTH OF PROFILE	135 x 89 mm / 5.31" x 3.50"
AUTO BRAKE WINCH	Ref. AL-KO 900
MINIMUM LOAD WEIGHT	20 kg / 44.09 lb
MADE WITH	ALUMINIUM - STEEL
ALLOY	EN-AW 6082 T6 - S235 JRH
COLOUR	BLACK
COMPLIES WITH	DGUV Regulation 17&18, DGUV Rule 115-002, DIN 56950-1, 2006/42/CE



GUIL®

ULK 500

MADE IN SPAIN



LINE ARRAY

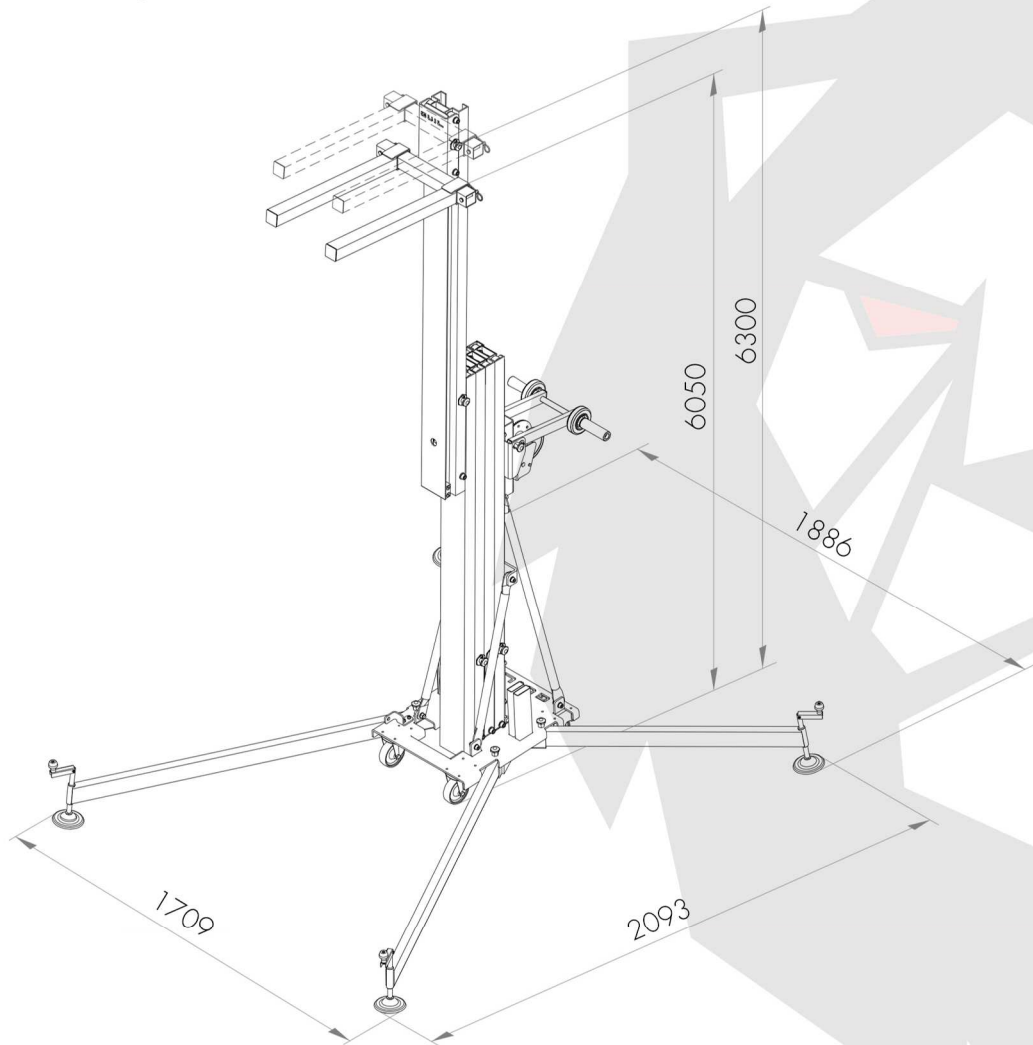
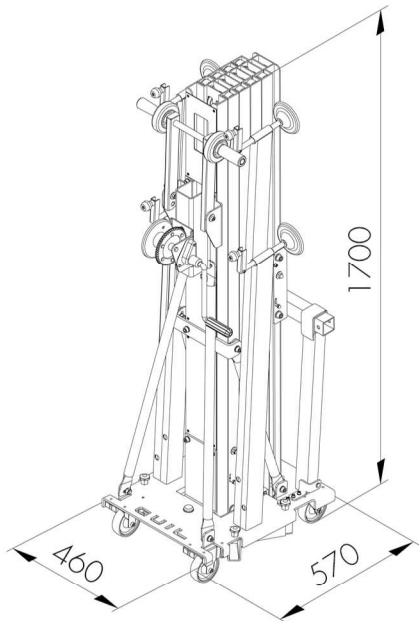
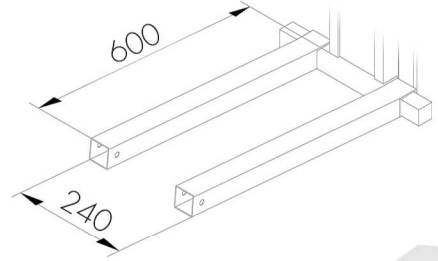
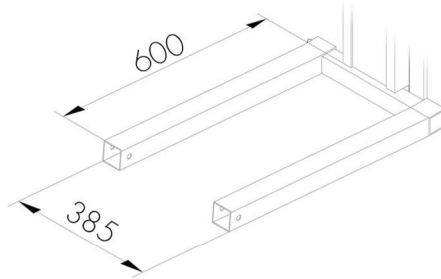

ADAPTORS FOR ULK TOWERS

ADAPTORS TO FLY LINE ARRAY SYSTEMS

SWIVEL ADAPTOR TO FIT TRUSSES TO ULK TOWERS



Ref. **ULK-A6**



Ref. **ULK-A4**



Ref. **ULK-A10**

360°



GUIL®

LIFTING TOWERS (FRONT-LOADER)

ULK



DGUV Regulation 17&18

What makes our towers different?



Mast Section Unblocking System (MSU)



Automatic Safety Blocking System (ASB)



Auto-brake Winch (AL-KO 900)
Complies with CE Machinery Directives.



Internal Pendulum Brake System (IPB)

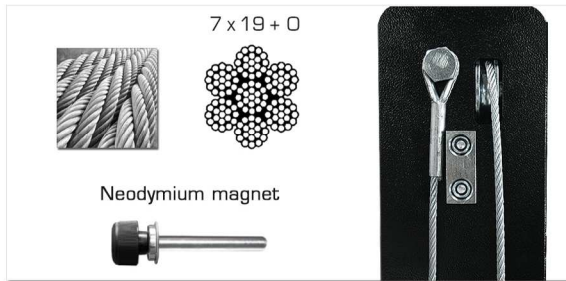

Reinforced Aluminium Sections. Galvanised steel wire rope. Stainless steel magnetic fastener bolts (Neodymium).



More mast overlap.
Prevent fishing rod effect.



4 heavy-duty wheels (Ø100mm) with aluminium core & steel fastening plates (secured by 4 bolts each).
Spirit level



60 x 60 mm Reinforced forks. Maximum strength.
Adjustable & detachable design.



Cable resend system with steel pulleys.



Fitted with 4 stabiliser braces for greater lift stability.



Husillos niveladores de doble paso y velocidad con discos cromados con caucho antideslizante.



Steel plate to reinforce the securing of the mast sections to the base.
Integrated manual holder.

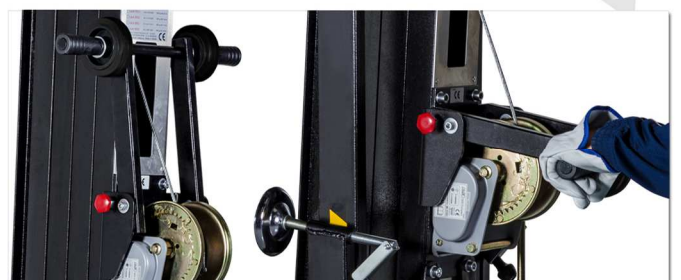

Fold-away handles with Ø100mm wheels for horizontal transportation & loading into vehicles.