



GUIL®

Since 1983

TELESCOPIC LIFTING TOWERS

ELC-785



Telescopic lifting tower designed and certified to lift loads of up to **300 kg** (661 lb) to a maximum height of **5.22 m** (17 ft). Equipped with autobrake double-handled winch to lift the load more quickly and conveniently.



SPECIFICATIONS ELC-785

- ▶ Maximum height: **5.22 m** | 17 ft
- ▶ Maximum Load: **300 kg** | 661 lb
- ▶ Safety System: **ASB System (Automatic Safety Blocking System)**
- ▶ Brake Winch: **Double-handled**
- ▶ Footprint: **Ø 225 cm** | 7 ft 4.6 in
- ▶ Folded Dimensions: Height: **1.77 m** | 5 ft 10 in
Base: **45 x 45 cm** | 1 ft 5.7 in x 1 ft 5.7 in
- ▶ Wheels: **4 wheels with brakes and bearings**

Secured to the base with 4 fixing points

- ▶ Material: **Steel**
- ▶ Net Weight: **102.5 kg** | 226 lb
- ▶ Adaptors: **Ø 55 mm** | Ø 0.18 ft
- ▶ Complies with Standards:
 - EN 17206 (Replaces DIN 56950-1)
 - DGUV 17 & 18
 - DGUV Rule 115-002 (Formerly BGV-C1)
 - 2006/42/CE





SAFETY SYSTEMS

ELC-785 has **two safety systems** which guarantee maximum reliability during the lifting and lowering procedure.

1.- Automatic brake winch with two handles: Its auto-block system ensures the load remains at the required height; once the required height is reached, the braking mechanism blocks the load when the handle is released.

2.- ASB System (Automatic Safety Blocking System): A Rack-and-Bolt safety system with safety bolts. In the extreme case of cable breakage, the safety bolt would immediately block the mast, stopping the load from falling.



ELC-785 telescopic lifting towers comply with the safety requirements according to the following Standards and Regulations:

- **EN 17206 (Replaces DIN 56950-1):** Entertainment technology - Machinery for stages and other production areas - Safety requirements and inspections.
- **DGVU 17 & 18, DGVU Rule 115-002 (Formerly BGV-C1):**
 - **DGVU Regulations 17 & 18:** Accident prevention regulation. Event and production facilities for scenic presentation.
 - **DGVU Rule 115-002:** Staging and Production Facilities for the Entertainment Industry.
- **Directive 2006/42/CE** on machinery that establish "Essential health and safety requirements relating to the design and construction of machinery".

The ELC-785 lifting tower is manufactured with the most advanced welding equipment which guarantees the highest level of safety and strength, complying with the lightweight, sturdiness and manoeuvrability requirements needed to lift heavy loads.

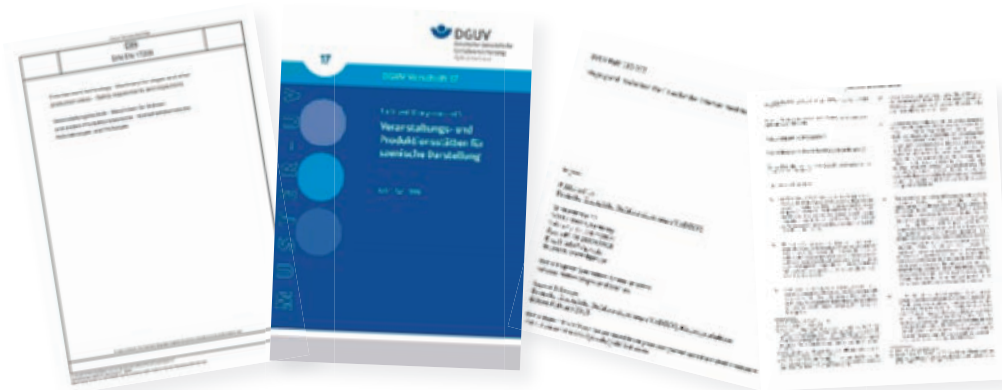



GUIL®

Since 1983

TELESCOPIC LIFTING TOWERS

ELC-785



MAST SECTIONS

The lifting tower consists of 4 high-resistance steel profiles finished in special epoxy paint for outdoor use. Its finish allows the lifting tower to be set up outside, ensuring its good upkeep and durability.



The masts are equipped with:

- a) **Oversized welded reinforced ending** which strengthens the mast, with an ergonomic metal pressure knob.
- b) **Internal cushioning system** to prevent wobbling of the mast sections when extended (on all four sides).
- c) **Double drawback pulley**
- d) **Pulley protectors** which reduce the chance of damage to the pulleys during handling and transportation, at the same time preventing the cable from coming off the pulleys.

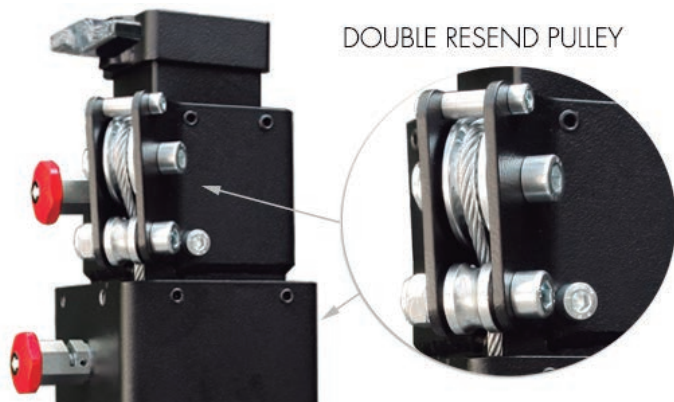

DOUBLE RESEND PULLEY





GUIL®

Since 1983

TELESCOPIC LIFTING TOWERS

ELC-785



BASE SECTION

The reinforced base of 45 x 45 cm is fitted with four rectangular legs equipped with levelling screw-jacks with non-slip chromed steel and injected rubber discs which guarantee a perfect grip on all kinds of surface.

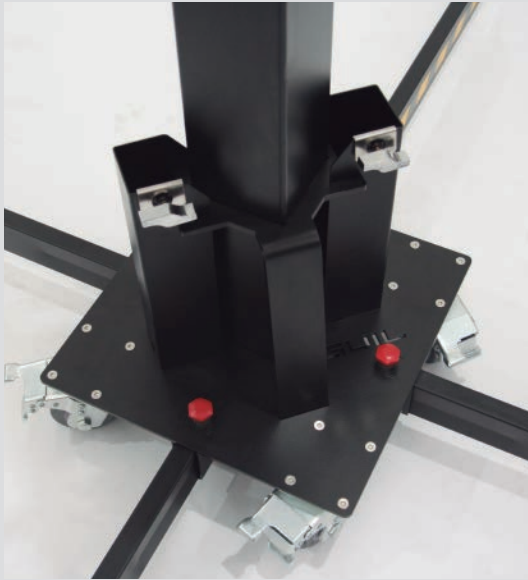

The base is provided with four swivel wheels with brake and bearings which permit the tower to be transported more smoothly and comfortably. The wheels are fastened to the base with fastening plates, with four screws per wheel; this system ensures the best possible fastening, even in jobs where the tower must be transported over irregular surfaces.

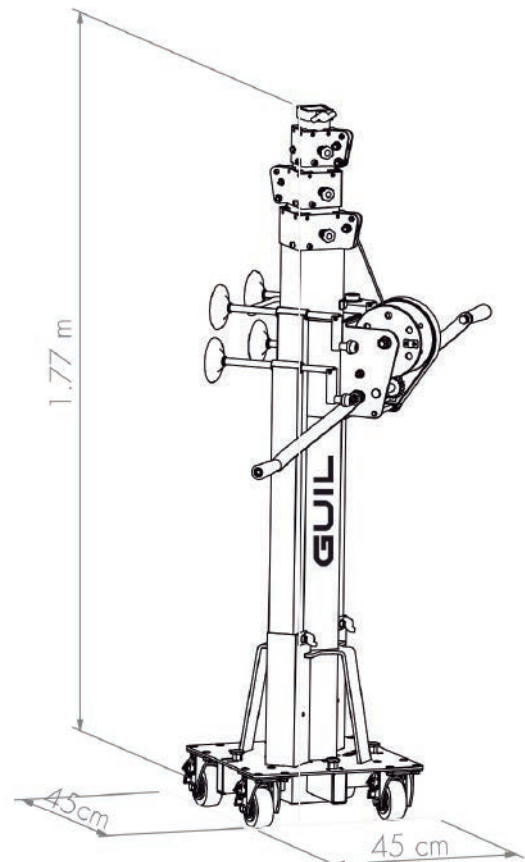
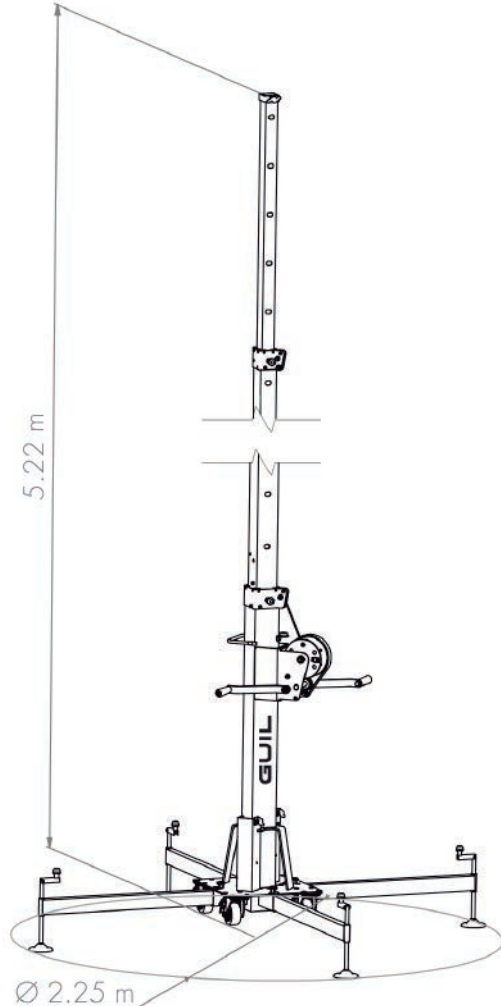



LIFTING PROCESS

The load is lifted using a double-handled autobrake manual winch. The telescopic stages of the tower are kept at the required height by simply ceasing to turn the handles: the braking mechanism acts, blocking the load in place.

The double-handled winch system allows the load to be lifted more quickly and conveniently.

The sections are raised by sets of pulleys with bearings and a galvanised steel cable (Composition: 7x19+0) specially designed to lift loads.



TRANSPORT

The ELC-785 towers are equipped with a handle and four swivel wheels with brake and bearings to make handling and transporting it easy.

During transport, the four legs are kept in the storage cassettes and secured there with a knob and plate to avoid marking the leg.

The two winch handles can be detached for transport and storage.



The tower is provided with a **spirit level** to allow it to be vertically adjusted.



DECLARACIÓN CE DE CONFORMIDAD EC DECLARATION OF CONFORMITY



El fabricante:
The manufacturer:

GUIL®

GUIL Accesorios Música S.L.

P.I. La Creu C/ Ismael Tomás Alacreu, 28
46250 L'Alcúdia –Valencia – SPAIN

Declara que el modelo:
Declares that the model:

Torre de elevación telescópica / *Telescopic lifting tower*

Ref.	Carga Máx. / <i>Max. Weight</i>	Altura Máx. / <i>Max. Height</i>
ELC-785	300 kg	5.22 m

Cumple con los requerimientos de las siguientes normativas:
Complies with the requirements according to the following standards:

- **2006/42/CE**
- **EN 17206**
- **DGUV Regulations 17 and 18**
- **DGUV Rule 115-002**

La persona facultada para elaborar el expediente técnico es:
The qualified person to create the technical report is:

Salvador Gascó García
P.I. La Creu C/Ismael Tomás Alacreu, 28
46250 – L'Alcúdia, Valencia (SPAIN)

Este producto ha sido sometido a los controles de seguridad y pruebas de resistencia realizadas en la fábrica de producción.

This product has been submitted by the manufacturer to a factory production control and to the further testing of samples taken at the factory.

Firmado:
Signed:

ES B96498829
P.I. LA CREU C/ ISMAEL TOMAS ALACREU, 28
46250 L'ALCUDIA (VALENCIA) SPAIN
Tel. + 34 962996500 Fax. + 34 962540833
www.guil.es info@guil.es sales@guil.es

Fecha de emission:
Issued on: **09/01/2024**

Eduardo Hinarejos Chinchilla
(Director general / *General manager*)

El presente certificado es válido salvo suspensión o retirada notificada con tiempo.
This Certificate is valid unless it is cancelled or withdraw upon written notification.